

Specifications

MODELS	GS™-2032		GS™-2632		GS™-3232	
	US	Metric	US	Metric	US	Metric
Working height maximum*	26 ft	8.10 m	32 ft	9.92 m	38 ft	11.75 m
A Platform height maximum	20 ft	6.10 m	26 ft	7.92 m	32 ft	9.75 m
B Platform height stowed	3 ft 4.5 in	1.03 m	3 ft 9.5 in	1.16 m	4 ft 2.75 in	1.29 m
C Platform length - outside	7 ft 5 in	2.26 m	7 ft 5 in	2.26 m	7 ft 5 in	2.26 m
extended	10 ft 5 in	3.18 m	10 ft 5 in	3.18 m	10 ft 5 in	3.18 m
Slide-out platform extension deck	3 ft	.91 m	3 ft	.91 m	3 ft	.91 m
D Platform width - outside	2 ft 8 in	.81 m	2 ft 8 in	.81 m	2 ft 8 in	.81 m
Guardrail height: fixed rails	3 ft 3 in	.99 m	—	—	—	—
fold down rails (CE)	3 ft 7 in	1.10 m	3 ft 7 in	1.10 m	3 ft 7 in	1.10 m
Toeboard height	6 in	.15 m	6 in	.15 m	6 in	.15 m
E Height - stowed						
fixed rails	6 ft 8 in	2.03 m	—	—	—	—
folding guardrails (CE)	7 ft	2.13 m	7 ft 5 in	2.26 m	8 ft	2.43 m
rails folded	5 ft 9 in	1.75 m	6 ft 3 in	1.91 m	6 ft 8 in	2.03 m
F Length - stowed	8 ft	2.44 m	8 ft	2.44 m	8 ft	2.43 m
Length - extended	10 ft 11 in	3.33 m	10 ft 11 in	3.33 m	10 ft 11 in	3.33 m
G Width	2 ft 8 in	.81 m	2 ft 8 in	.81 m	2 ft 8 in	.81 m
H Wheelbase	6 ft 1 in	1.85 m	6 ft 1 in	1.85 m	6 ft 1 in	1.85 m
I Ground clearance - center	3.5 in	.09 m	3.5 in	.09 m	3.5 in	.09 m
J - with pothole guards deployed	.75 in	.02 m	.75 in	.02 m	.75 in	.02 m

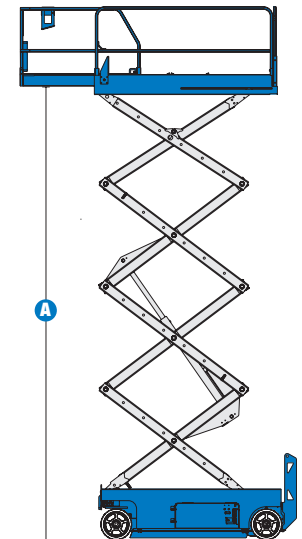
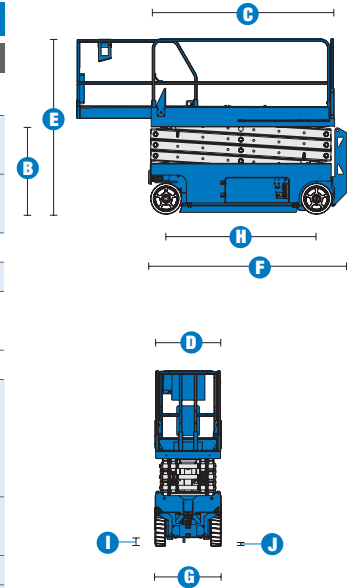

PRODUCTIVITY						
Maximum platform occupancy**	2	2	2	2	2	2
Lift capacity	800 lbs	363 kg	500 lbs	227 kg	500 lbs	227 kg
Extension deck capacity	250 lbs	113 kg	250 lbs	113 kg	250 lbs	113 kg
Drive height	full height		full height		22 ft	6.71 m
Drive speed - stowed	2.2 mph	3.5 km/h	2.2 mph	3.5 km/h	2.2 mph	3.5 km/h
Drive speed - raised	0.5 mph	0.8 km/h	0.5 mph	0.8 km/h	0.5 mph	0.8 km/h
Gradeability - stowed***	30%		25%		25%	
Maximum outrigger leveling: front to back	—		—		3°	
side to side	—		—		5°	
Turning radius - inside	zero	zero	zero	zero	zero	zero
Turning radius - outside	7 ft	2.13 m	7 ft	2.13 m	7 ft	2.13 m
Raise / lower speed	30 / 34 sec	30 / 34 sec	30 / 40 sec	30 / 40 sec	57 / 40 sec	57 / 40 sec
Controls	proportional		proportional		proportional	
Drive	dual front wheel		dual front wheel		dual front wheel	
Multiple disc brakes	dual rear wheel		dual rear wheel		dual rear wheel	
Tires - solid non-marking	15 x 5 x 11 in	38 x 13 x 28 cm	15 x 5 x 11 in	38 x 13 x 28 cm	15 x 5 x 11 in	38 x 13 x 28 cm

POWER						
Power source	24 V DC (four 6V 225 Ah batteries)		24 V DC (four 6V 225 Ah batteries)		24 V DC (four 6V 225 Ah batteries)	
Hydraulic system capacity	3.75 gal	14.2 L	3.75 gal	14.2 L	3.75 gal	14.2 L

WEIGHT****						
ANSI, CSA	3,574 lbs	1,621 kg	4,413 lbs	2,002 kg	5,185 lbs	2,352 kg
CE, AUS	4,024 lbs	1,825 kg	4,313 lbs	1,956 kg	5,185 lbs	2,352 kg

STANDARDS COMPLIANCE ANSI A92.6, CSA B354.2, CE Compliance, AS 1418.10

* The metric equivalent of working height adds 2 m to platform height. U.S. adds 6 ft to platform height.
 ** CE/AUS markets: GS-2632 and GS-3232 indoor use only. GS-2032 outdoor use-one person maximum occupancy.
 *** Gradeability applies to driving on slopes. See operator's manual for details regarding slope ratings.
 **** Weight will vary depending on options and/or country standards.